

# STANDARD OPERATING PROCEDURE

**Counterweight Installation and Removal On Loading Tools**

Document Number: 960C-SOP-311

Original Approval Date: Jun 14, 2021

Revision Number: 2

Page 1 of 10

Latest Revision Date: Jan 24, 2024

Next Revision Date: Jan 24, 2027

Document Approval Level: 4

\*This document is not controlled if printed\*

## COUNTERWEIGHT INSTALLATION AND REMOVAL ON LOADING TOOLS

						
2	APP	Jan 24, 2024	Approved	Andre Brule	Lisa Norris	Tammy Siver
1	APP	Jun 14, 2021	Approved	Andre Brule	Tammy Siver	Gilbert Schreyer
<b>Rev</b>	<b>Status</b>	<b>Rev. Date</b>	<b>Status Description</b>	<b>Prepared by</b>	<b>Reviewed by</b>	<b>Approved by</b>

# STANDARD OPERATING PROCEDURE

Counterweight Installation and Removal On Loading Tools		Document Number: 960C-SOP-311
Original Approval Date: Jun 14, 2021	Revision Number: 2	Page 2 of 10
Latest Revision Date: Jan 24, 2024	Next Revision Date: Jan 24, 2027	Document Approval Level: 4

\*This document is not controlled if printed\*

*The following is a step-by-step procedure on how to complete a specific task or meet a facility specific requirement. Standard Operating Procedures (SOPs) are written for all identified critical tasks. By virtue of the hazard or complexity associated with critical tasks it is paramount that the SOP be followed as written. SOPs contain a listing of high-level hazards associated with the task, for detailed hazard analysis reference the applicable Task Hazard Assessments. SOPs do not replace the requirements contained in the company Standards, Codes, and Processes nor does it replace the need to comply with required legislation. Section 8.0 references documentation that the worker shall understand before work commences.*

## 1.0 PURPOSE

- To establish a company standard to safely and effectively carry out work as it applies to counterweight installation and removal on loading tools such as shovels and excavators.

## 2.0 SCOPE AND APPLICATION

- This document applies to all company Heavy Construction Mining operations. Ensure all site-specific requirements are being met or exceeded before performing the task.

## 3.0 HAZARDS AND CONTROLS

- Not qualified and/or trained to remove or install counterweights.
  - Prior to starting the task, workers **must** carefully read and understand all instructions before attempting to remove or install equipment counterweights. OEM/manufacture's procedures and/or instructions **must** be followed during the removal and/or installation process.
  - Only competent and trained workers will participate in the removal and/or installation of equipment counterweights.
- Unplanned movement of equipment and/or counterweight resulting in significant injury or damage.
  - Before working on counterweights, read and understand the instructions and warnings in the machine specific OEM/manufacture's procedures.
  - Use flagging and/or barricades to prevent unauthorized equipment and/or personnel from entering the work area (follow 960C-SOP-004-Flagging, Tagging, and Barricading Hazardous Areas).
  - Ensure the machine is on a firm, flat level surface and the area is clear of any obstructions and/or hazards.
  - Ensure the counterweight is secure / rigged up and under tension prior to removing / disconnecting the counterweight hardware (bolts supporting the counterweight to the equipment).
  - Workers will maintain a safe distance from a suspended counterweight while in motion of at least 3 meters (10 feet) (see Appendix A). The suspended load **must** be controlled using tag lines.
  - Do not raise the suspended counterweight more than is necessary (keep the load close to the ground).

# STANDARD OPERATING PROCEDURE

<b>Counterweight Installation and Removal On Loading Tools</b>		Document Number: 960C-SOP-311
Original Approval Date: Jun 14, 2021	Revision Number: 2	Page 3 of 10
Latest Revision Date: Jan 24, 2024	Next Revision Date: Jan 24, 2027	Document Approval Level: 4

\*This document is not controlled if printed\*

- o When lifting the counterweight, the operator will immediately stop the equipment if sight is lost between the operator and signal person.
- Unclear communication resulting in personal injury and/or property damage.
  - o Confirm methods of communication (radio, hand signals, horns, etc.) before the task.
  - o Equipment will STOP immediately if operator loses sight of primary spotter.
  - o Equipment operators will only follow signals from primary spotter unless a STOP signal is issued.
  - o Equipment operators will not respond to unclear signals.
  - o Follow 962C-SOP-008 - Signaling Equipment.
- Equipment & rigging failure or malfunction causing personal injury and/or property damage.
  - o Know the weight of the counterweight prior to the task.
  - o Inspect all equipment used to hoist the counterweight (e.g. cranes or overhead cranes).
  - o Thoroughly inspect all rigging components prior to use (e.g. lifting eyes, shackles, slings, and cables, etc.).
  - o Ensure all rigging, including shackles, hooks and slings are rated and/or exceed the lifting capacity required for the load to be lifted.
  - o Only competent personnel will rig and signal loads.
  - o All personnel will maintain a safe distance of at least 3 meters (10 feet) (see Appendix A) from the suspended load. No worker shall stand or pass under a raised counterweight.
  - o Tagline(s) will be used when removing and/or installing counterweights. Tag lines can move suddenly, unexpectedly, and very forcefully. Always handle them with gloves. Never wrap a tag line around your wrist or forearm or in any other manner where you cannot instantly release your grip.
  - o Follow 950C-C-008 Cranes, Hoists and Rigging Code.
- Unauthorized personnel operating equipment while counterweight is being removed and/or installed.
  - o Only trained, competent and authorized personnel shall operate equipment.
  - o Equipment will be locked out/ tagged out to protect against accidental or inadvertent operation unless the manufacturer's procedures indicate otherwise. Flagging and/or barricades will also be used to identify the work area to prevent unauthorized personnel from entering the work area.

# STANDARD OPERATING PROCEDURE

Counterweight Installation and Removal On Loading Tools		Document Number: 960C-SOP-311
Original Approval Date: Jun 14, 2021	Revision Number: 2	Page 4 of 10
Latest Revision Date: Jan 24, 2024	Next Revision Date: Jan 24, 2027	Document Approval Level: 4

\*This document is not controlled if printed\*

- o Follow 960C-SOP-111 - Live Work - Working on Equipment while Running & Live Work Checklist.
- Falling when working from heights resulting in injury or death.
  - o Worker must assess the risks associated with task and identify, control, or eliminate any fall hazards. Worker will notify supervisor if there are any fall hazards outside of their control.
  - o Fall Protection must be used when a worker is working above 1.8 meters (6 feet) or when there is a possibility of injury due to the fall. The worker is required to fill out a fall protection plan.
  - o Supervisor must ensure the worker is trained and competent prior to using fall protection equipment.
  - o Fall protection equipment must be inspected prior to each use.
  - o Follow 950C-C-016 - Fall Protection Code.
- Built in hydraulic lift system failure or malfunction causing personal injury, death and/or property damage.
  - o Use flagging and/or barricades to prevent unauthorized equipment and/or personnel from entering the work area (follow 960C-SOP-004 Flagging, Tagging, and Barricading Hazardous Areas).
  - o Before working on counterweights with a built-in hydraulic lift system read and understand the instructions and warnings in the machine specific OEM/manufacture procedures.
  - o Workers must conduct a visual inspection of the hydraulic lift system, check for signs of hydraulic oil leaking from the counterweight removal system (oil leaks may be a sign of a potential system failure and needs to be corrected before removing the counterweight mounting bolts).
  - o Workers must monitor the lowering of the counterweight, if at any time the counterweight stops moving during the process, stop and correct the issue (follow the OEM/manufacture procedures).
  - o All personnel will maintain a safe distance of at least 3 meters (10 feet) from the counterweight being lowered or installed using the hydraulic lift system (see Appendix B).
- Hydraulic oil injecting through the skin resulting in loss of limb, personal injury and/or death.
  - o Workers must conduct a **visual** inspection (inspections may vary based on the type of equipment, refer to the OEM/manufacture's procedures for recommendations).
  - o Do not touch or get near a pressurized hydraulic hose assembly with any part of your body.

## 4.0 CHECKLIST

- Attend all preparatory meetings (IE: daily PSI; job scope; review of JSA's and SOP's for the job).
- Complete FLRA cards before starting the work.
- Ensure all personnel involved in the task are aware of the hazards and the controls to be used, as identified in the SOP's; JSA's; and FLRA's.

# STANDARD OPERATING PROCEDURE

Counterweight Installation and Removal On Loading Tools

Document Number: 960C-SOP-311

Original Approval Date: Jun 14, 2021

Revision Number: 2

Page 5 of 10

Latest Revision Date: Jan 24, 2024

Next Revision Date: Jan 24, 2027

Document Approval Level: 4

\*This document is not controlled if printed\*

- Conduct a pre-job inspection of all equipment to be worked on and tools to be used.
- Standard of Training required for working on this job: On-the job training.**

## 5.0 DEFINITIONS

### 5.1 Company

- Means North American Construction Group Ltd. (NACG) and all directly or indirectly owned subsidiary companies, including joint ventures.

### 5.2 Company Personnel

- Includes the Company's employees, officers, directors, agents, associates, consultants/contractors, temporary employees, and third-party processors.

### 5.3 Counterweight

- A counterweight is a weight that, by applying an opposite force, provides balance and stability of a mechanical system. The purpose of a counterweight is to make lifting the load faster and more efficient, which saves energy and is less taxing on the lifting machine.

### 5.4 HSE

- Refers to the Health, Safety & Environment department.

### 5.5 Line of fire Hazard

- Travel path of a moving object or the release of hazardous energy intersects with an individual's body. Three major categories of line of fire incidents are caught-in or between incidents, struck-by incidents, and released energy incidents.

### 5.6 Pinch Point

- Any point where it is possible for a body part to be caught between moving and stationary portions of equipment and/or load.

## 6.0 PROCEDURE

### 6.1 General Safety Procedure

- 1) Supervisor and workers will discuss the task and plan the safest way to approach the work. Workers will complete a hazard assessment such as an FLRA card to identify hazards and controls.
- 2) Supervisors must ensure workers understand the process for removing and installing machine counterweights using either the manual removal/install system or built in hydraulic lift.
- 3) Supervisors must ensure workers are trained and competent to operate equipment.
- 4) Position the machine on a firm, flat level surface. Ensure the area is clear of any obstructions and/or hazards. Use flagging/tagging and/or hard barricades to prevent unauthorized personnel from entering the area.
- 5) Carefully read and understand all OEM/manufacture procedures/instructions before attempting to remove and/or install machine counterweights. Follow procedures specific to the equipment you are working on.

# STANDARD OPERATING PROCEDURE

Counterweight Installation and Removal On Loading Tools		Document Number: 960C-SOP-311
Original Approval Date: Jun 14, 2021	Revision Number: 2	Page 6 of 10
Latest Revision Date: Jan 24, 2024	Next Revision Date: Jan 24, 2027	Document Approval Level: 4

\*This document is not controlled if printed\*

- 6) Maintain good housekeeping throughout the task and clean up the area once the task is complete.

## 6.1.1 Machines Equipped with Standard Counterweights (Manual Removal/Install System)

- 1) Isolate hazardous energy and ensure the equipment is locked out / tagged out prior to removing and/or installing the machine counterweight (follow 960C-SOP-111 - Live Work - Working on Equipment while Running & Live Work Checklist).
- 1) Equipment operators and ground personnel will confirm method of communication (radio, hand signals, horns, etc.) prior to the task.
- 2) Inspect all equipment used to hoist counterweights (e.g. cranes or overhead cranes etc.). Ensure the equipment used is rated for the load.
- 3) Thoroughly inspect all rigging components prior to use (e.g. lifting eyes, shackles, slings, and cables, etc.). Ensure all rigging, including shackles, hooks and slings are rated and/or exceeds the lifting capacity required for the load to be lifted.
- 4) Refer to OEM/manufacture procedures, for specific weight information. Always use rigging and equipment rated for the load.
- 5) If equipped, disconnect the wiring for the rear-view camera. Refer to the OEM/manufacture procedures.
- 6) Ensure the counterweight is secure / rigged up and under tension prior to removing or disconnecting the counterweight hardware (bolts supporting the counterweight to the equipment).
- 7) Ensure counterweight is set on suitable supports (e.g. dunnage, trailer etc.).

## 6.1.2 Machines Equipped with Counterweight Removal/Install Systems (Built in Hydraulic Lift)

- 2) Personnel involved in the task will confirm method of communication (radio, hand signals, horns, etc.).
- 3) Complete a Live Work Checklist and review with all personnel involved in the task (follow 960C-SOP-111 - Live Work - Working on Equipment while Running & Live Work Checklist).
- 4) Place a "Live Work or Live Testing" sign or tag on the machine where it is visible to anyone approaching the controls or cab.
- 5) Conduct a visual inspection of the hydraulic oil system used to remove or install the counterweight.

**NOTE:** When the removal cylinder is used to lower the counterweight, the counterweight can wedge against the machine frame which stops the downward movement of the counterweight. Since the removal cylinder continues to retract and the counterweight stopped, slack in the chain for the removal cylinder will occur.

The counterweight can suddenly fall due to the slack in the chain which could result in, equipment damage, personal injury or death. Monitor the lowering of the counterweight when the counterweight is being lowered

# STANDARD OPERATING PROCEDURE

Counterweight Installation and Removal On Loading Tools		Document Number: 960C-SOP-311
Original Approval Date: Jun 14, 2021	Revision Number: 2	Page 7 of 10
Latest Revision Date: Jan 24, 2024	Next Revision Date: Jan 24, 2027	Document Approval Level: 4

\*This document is not controlled if printed\*

with the removal cylinder. If the removal cylinder is retracted and the downward movement of the counterweight stops, stop the lowering procedure, and correct the wedging of the counterweight against the machine frame.

- 6) Use an appropriate lifting device (e.g. cranes, overhead cranes, loader, forklift). to set the counterweight on suitable supports.

## 7.0 NOTES

If this task is to be done by a method different than described in this SOP, the work must **STOP**, and the alternate method must be **DOCUMENTED** with an adequate hazard assessment tool such as a JSA. The document must be **APPROVED** by a supervisor before such procedures are implemented.

## 8.0 REFERENCES

- Alberta Occupational Health and Safety Act, Regulation and Code – Part 6 Cranes, Hoists and Lifting Devices
- Alberta Occupational Health and Safety Act, Regulation and Code – Part 9 Sections 138 to 161 – Fall Protection
- Alberta Occupational Health and Safety Act, Regulation and Code – Part 15, Section 212 (2) Managing the Control of Hazardous Energy - Isolation
- Alberta Occupational Health and Safety Act, Regulation and Code – Part 21 Rigging
- Alberta Occupational Health and Safety Act, Regulation and Code – Part 23 Sections 346 – 348 Elevating Work Platforms
- 950C-C-008 - Cranes Hoist and Rigging Code
- 950C-C-013 - Equipment Guarding Code
- 950C-C-016 - Fall Protection Code
- 950C-C-022 - General Housekeeping Code
- 950C-C-028 Hazardous Energy Isolation Code
- 950C-C-049 - PPE - General Code
- 960C-SOP-004 - Flagging Tagging and Barricading Hazardous Areas
- 960C-SOP-020 - Mechanical Lifting Aids
- 960C-SOP-111 - Live Work - Working on Equipment while Running & Live Work Checklist
- 960C-SOP-504 - Hand Tools Use
- 962C-SOP-008 - Signaling Equipment
- 962C-SOP-009 - Manual Lifting and Carrying Heavy Objects
- Examples of machine specific counterweight removal procedures:
  - CAT - Counterweight Removal and Installation – multiple machine types & models
  - EX1200-7 Counterweight Removal and Installation
  - Hitachi 3600-6 Counterweight Removal and Installation
  - Hitachi EX870-6 Counterweight Removal Device
  - Hitachi EX870-6 Fixed Counterweight Removal and Installation
  - Hitachi EX1900-6 Counterweight Removal and Installation
  - Hitachi EX2500-6 Counterweight Removal and Installation
  - Hitachi EX5500-6 Counterweight Install

# STANDARD OPERATING PROCEDURE

Counterweight Installation and Removal On Loading Tools

Document Number: 960C-SOP-311

Original Approval Date: Jun 14, 2021

Revision Number: 2

Page 8 of 10

Latest Revision Date: Jan 24, 2024

Next Revision Date: Jan 24, 2027

Document Approval Level: 4

\*This document is not controlled if printed\*

- Hitachi EX5500-6 Counterweight Removal and Installation
- Hitachi EX8000-6 Counterweight Remove and Install
- Komatsu PC2000-8

## 9.0 APPENDICES

- Appendix A - Handling Suspended Loads
- Appendix B - Control Zone for Built in Hydraulic Lift



# STANDARD OPERATING PROCEDURE

Counterweight Installation and Removal On Loading Tools

Document Number: 960C-SOP-311

Original Approval Date: Jun 14, 2021

Revision Number: 2

Page 9 of 10

Latest Revision Date: Jan 24, 2024

Next Revision Date: Jan 24, 2027

Document Approval Level: 4

\*This document is not controlled if printed\*

## Appendix A Handling Suspended Loads

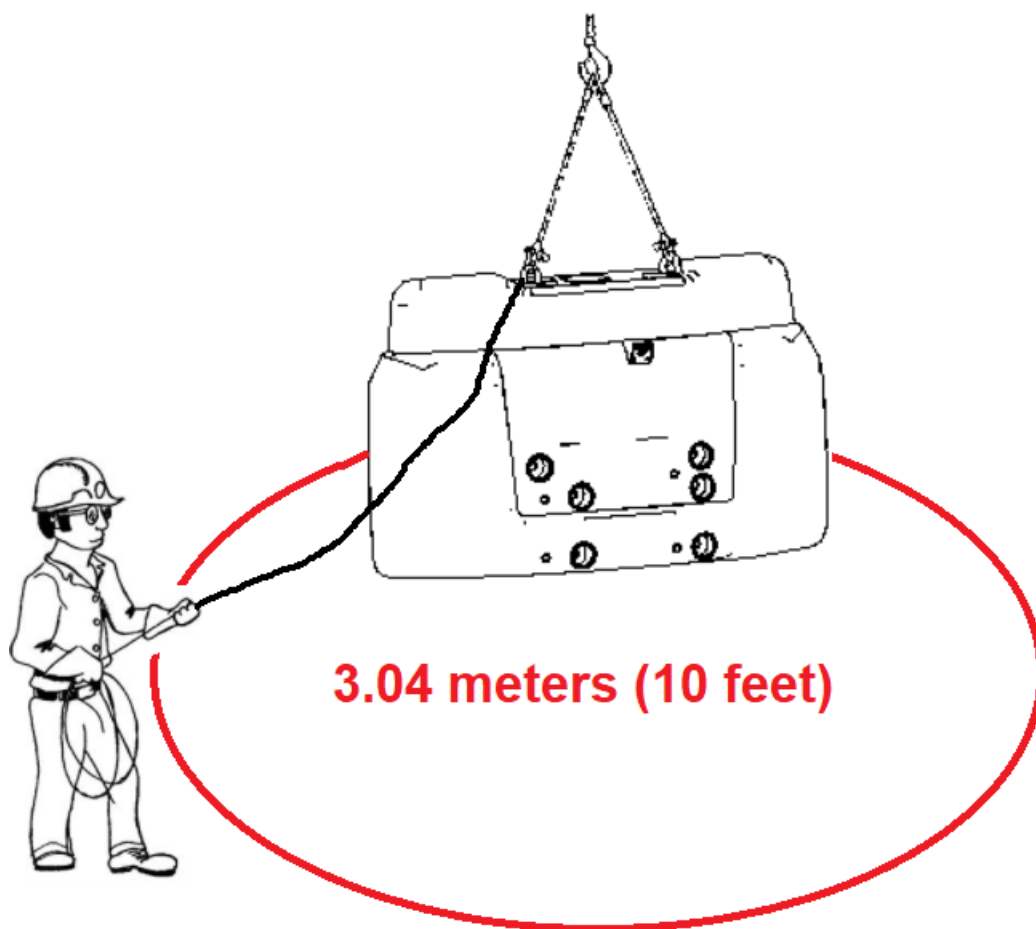

# STANDARD OPERATING PROCEDURE

Counterweight Installation and Removal On Loading Tools

Document Number: 960C-SOP-311

Original Approval Date: Jun 14, 2021

Revision Number: 2

Page 10 of 10

Latest Revision Date: Jan 24, 2024

Next Revision Date: Jan 24, 2027

Document Approval Level: 4

\*This document is not controlled if printed\*

## Appendix B Control Zone for Built in Hydraulic Lift

